

PRINT DIST
 18
 2

DIMENSIONS IN INCHES. DO NOT SCALE PRINT.

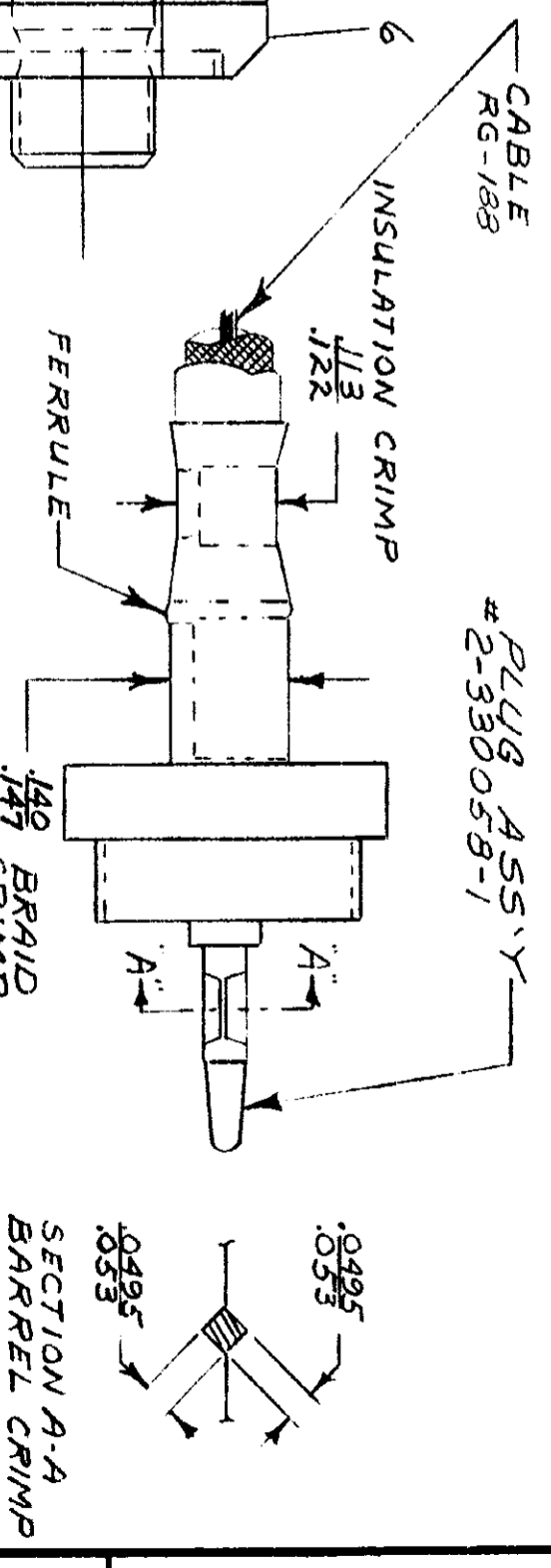
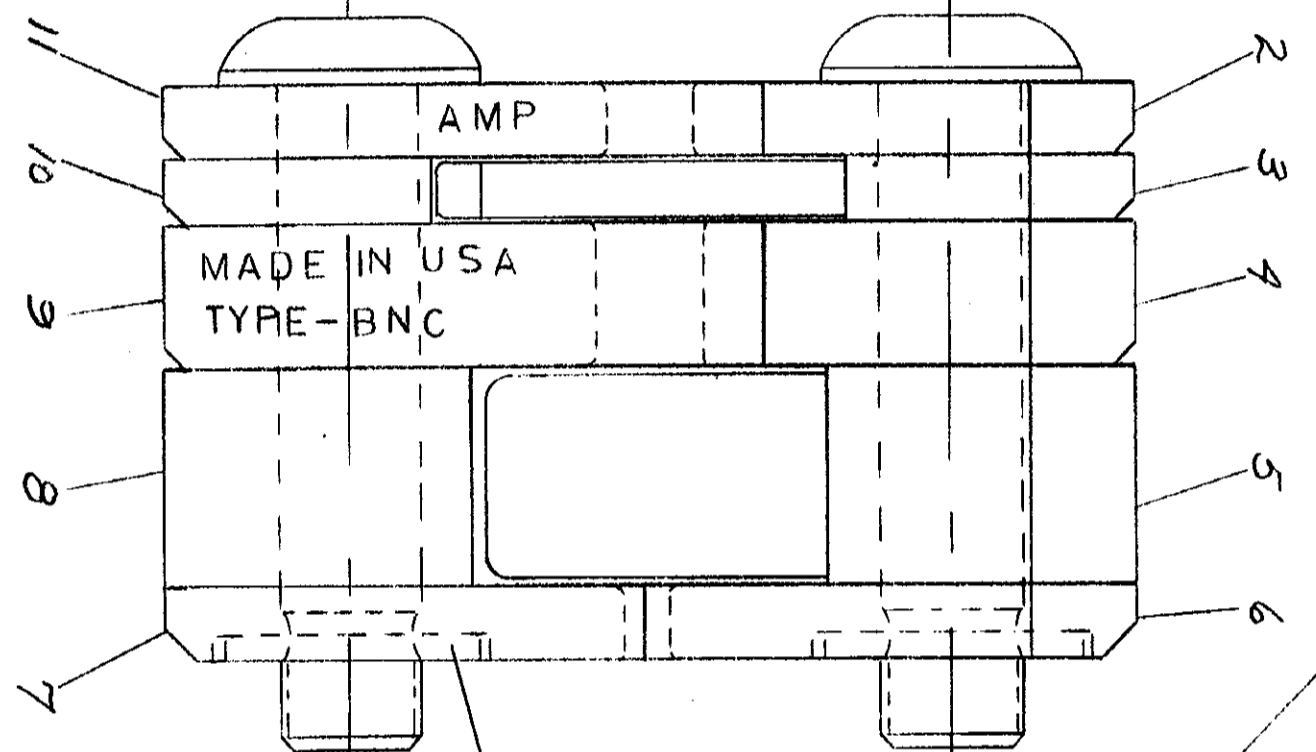
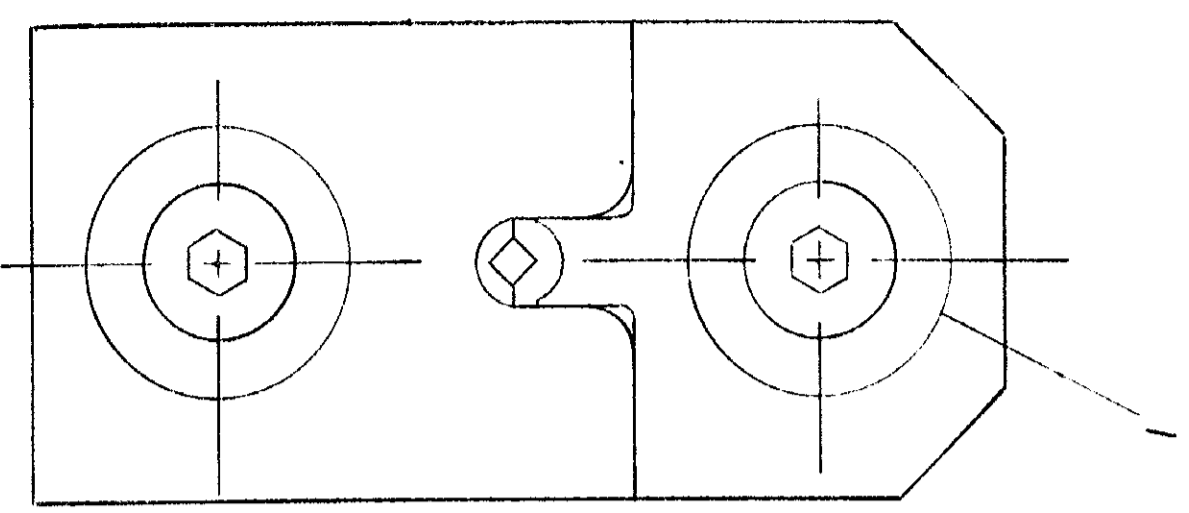

THE CRIMP DIM'S APPLY ONLY TO THE ABOVE COMBINATIONS.

METHOD OF GAGING CRIMP DIMENSIONS.

SUPERSEDED BY 15.2496

ITEM NO	QTY	DESCRIPTION	REMARKS
12	2	RETAINING RING	
11	1	INDENTER - INSULATION	
10	1	SPACER	
9	1	INDENTER - BRAID	
8	1	SPACER	
7	1	BARREL - INSERT - LOWER	
6	1	BARREL - INSERT - UPPER	
5	1	SPACER - SPECIAL	
4	1	ANVIL - BRAID	
3	1	EJECTOR	
2	1	ANVIL - INSULATION	
1	2	SCREW - SPECIAL	

NUMBER	REVISION RECORD	DR	CHK	DATE
69422				
C	SUPP BY 1.5.2496	KJF	BJF	8-27-78
B	REVISED	BS		8-7-78
A	REVISED	BS		9-28-78

DESCRIPTION	REQUIRED PER ASSEMBLY
69422	

©1967 BY AMP INCORPORATED. ALL RIGHTS RESERVED. AMP PRODUCTS COVERED BY PATENTS AND/OR PATENTS PENDING.

MATERIAL AND FINISH

CLASS: H

TYPE: BNC-COAX

LOC: M

NO: 69422

REV: C

WIRE - RANGE - INSULATION: RG-188

TOLERANCE EXCEPT AS NOTED: ± .015

SCALE: 4-1

NAME: DIE ASSY

DR: C Meyer 10-17-73

CHK: [Signature]

APP: [Signature]

A

B

C

D

7

6

5

4

3

2

1